

T1525

Straight Thermocouple Temperature Sensors with Ceramic Protective Tubes C799 without/with Transmitters 4 to 20 mA

- Thermocouple S, B (wire Ø0.5 mm)
- Measuring range 0 to +1300 °C ("S"), +300 to +1600 °C ("B")
- Accuracy class 2 to 3 according to EN 60584-2
- Spherical head form A according to DIN
- One protective tube of C799 ceramics
- Selectable protective tube lengths
- Thermometer is fixed with shift weld-on flange or with fixing shift pipe union
- Housing IP 55
- Optional headmounted programmable transmitter with output 4 to 20 mA, including circuit isolation version and II 1G EEx d IIC T1 ... T6 (ATEX)

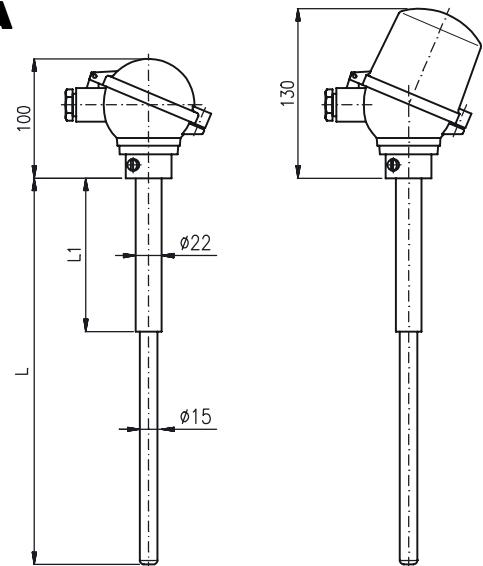

Application

Straight thermocouple temperature sensors T1525 are designed for remote measuring of temperature in furnaces, incinerating plants and the like. They are designed for mounting into furnace walls and other technologic plants. They can be supplied with or without 4 to 20 mA headmounted transmitter.

Description

A single or dual thermocouple type S or type B which is placed in capillary and in one protective tube of C799 ceramics and connected to a terminal block inside the spherical head form A according to DIN. There is made use of rise of thermoelectric voltage. Its size depends on a temperature difference between a measuring junction and a cold junction of the thermocouple. With a version with a transmitter the thermoelectric voltage is converted to a unified linear current signal of 4 to 20 mA. The thermometer should be mounted by a fixing shift pipe union or by a flange.

Technical Specifications

Thermocouple:

- S (PtRh10-Pt), accuracy class 2 according to EN 60584-2
- B (PtRh30-PtRh6), accuracy class 3 according to EN 60584-2

Measuring Range:

- 0 to +1300 °C (thermocouple S)
- +300 to +1600 °C (thermocouple B)

Output signal: linearized 4 to 20 mA ³⁾

Dielectric Strength: 500 V eff

Diameter of Wires: Ø0.5 mm

Materials:

- Head - Varnished Aluminium alloy
- Support tube Ø22x2 - Varnished carbon steel
- Protective tube Ø15x2.5 - C799 ceramics
- Insulation tube of T/C Ø8.5x1.5 - C799 ceramics

Typical Composition of C799 Ceramics:

99.7 % Al₂O₃

Porosity of C799 Ceramics:

No porosity

Housing:

IP 55

Operation Conditions

Maximal Temperature of Head:

- 150 °C (without transmitter)
- 80 °C (with transmitter PT-031 and P3301)
- 85 °C (with transmitter P5102, P5201 and P5310)

Other specifications

EMC (Electromagnetic Compatibility):

According to EN 61326-1:98 / A1:99

Weight:

a) without transmitters with head H1:

- Nominal length L:
- 500 ... 0.80 kg
 - 710 ... 0.90 kg
 - 800 ... 1.00 kg
 - 1000 ... 1.20 kg
 - 1400 ... 1.40 kg
 - 1600 ... 1.50 kg

b) with head H2 plus 0.03 kg

- c) with transmitter PT-031 plus 0.02 kg
 with transmitter P5102 plus 0.04 kg
 with transmitter P5201 plus 0.05 kg
 with transmitter P3301 plus 0.04 kg
 with transmitter P5310 plus 0.04 kg

Caution!

If the temperature sensor is being installed or replaced in operation it is necessary to insert it into a furnace tube gradually (see table) so as to prevent the ceramic protective tubes from cracking because of the heat stress caused by a rapid temperature change.

Working Temperature [°C]	1200	1400	1600
Velocity of shifting [mm/min]	200	60	20

If it is impossible to provide recommended velocity of shifting, sensors have to be slowly and evenly pre-heating.

¹⁾... Only for sensor with transmitter

Straight Thermocouple Temperature Sensors T1525 with Ceramic Protective Tubes C799

Electrical Connections

Type	Description		
◦ T1525-6 →	Straight Thermocouple Temperature Sensors with Ceramic Protective Tubes C799		
Code	Thermocouple	Measuring Range	Diameter of wires [mm]
◦ 26 →	1x"S" (PtRh10-Pt), Insulated	0 to +1300 °C	0.5
◦ 66	2x"S" (PtRh10-Pt), Insulated, Isolated Junctions	0 to +1300 °C	0.5
◦ 28	1x"B" (PtRh30-PtRh6), Insulated	+300 to +1600 °C	0.5
◦ 68	2x"B" (PtRh30-PtRh6), Insulated, Isolated Junctions	+300 to +1600 °C	0.5
◦ 99	Other		
Code	Accuracy Class according to EN 60584-2		
◦ 7 →	2 (Standard for Thermocouple "S")		
◦ 8	3 (Standard for Thermocouple "B")		
◦ 9	Other		
Code	Nominal Length L [mm]		
◦ 150	500		
◦ 171 →	710		
◦ 180	800		
◦ 210	1000		
◦ 214	1400		
◦ 216	1600		
◦ 999	Other		
Code	Protection Tube - Outside Diameter x Wall Thickness [mm]	Material	
◦ O1 →	∅15x2.5	C799 Ceramics	
◦ O9	Other		
Code	Support Tube - L1 Length [mm]	Material	
◦ N0 →	200 (Standard for Lengths 500, 710 and 800 mm)	Varnished Carbon Steel	
◦ N1	400 (Standard for Lengths 1000, 1400 and 1600 mm)	Varnished Carbon Steel	
◦ N9	Other		
Code	Head		
◦ H1 →	Al Alloy, Cable Outlet M20x1.5, Housing IP 55, with Terminal Board		
◦ H2 ¹	Al Alloy, with High Cap for Mounting of Transmitter into Cap, Cable Outlet M20x1.5, Housing IP 55, with Terminal Board		
◦ H9	Other		
OPTIONAL ACCESSORIES			
Code	Calibration		
◦ KTE3	Sensor Calibration in Three Customer's Given Temperature Points (0 to +1100 °C)		
◦ KTE9	Other		
Code	Fixing Flanges		
◦ P1 →	Fixing Shift Flange UP 03 (See Data Sheet No. 126)		
◦ P2	Fixing Shift Pipe Union UPS 22 M33 (See Data Sheet No. 126)		
◦ P9	Other		
Code	Transmitters for Headmounting		
• P5310	Programmable Transmitter P5310 with LHP Communication, Base Accuracy up to 0.1 % from Set Range (See Data Sheet No. 824)		
• PT-031	Programmable Transmitter for Thermoelectric Sensors PT-031, Base Accuracy 0.15 % from Input Range (See Data Sheet No. 471)		
• P5102	Programmable Transmitter P5102 H10, Base Accuracy to 0.07 % from Set Range (See Data Sheet No. 451)		
◦ P5102EEx	Intrinsically Safe Programmable Transmitter P5102 H10EEx, Base Accuracy to 0.07 % from Set Range (See Data Sheet No. 451)		
• P5201 →	Universal Programmable Transmitter P5201 H10 with Circuit Isolation, Base Accuracy to 0.05 % from Set Range (See Data Sheet No. 288)		
◦ P5201EEx	Intrinsically Safe Universal Programmable Transmitter P5201 H10EEx with Circuit Isolation, Base Accuracy to 0.05 % from Set Range (See Data Sheet No. 288)		
• P3301	Universal Programmable Transmitter P3301 SMART with Circuit Isolation, Base Accuracy to 0.065 % from Set Range HART Communication Interface (See Data Sheet No. 507)		

Example of Order: T1525-6 26 7 171 O1 N0 H1 P1 P5201 H10 RL 0 °C RH 350 °C ECL

• ... Ex Stock Version ° ... Marked Version can be Dispatched up to 10 Working Days

¹ ... Temperature of head with transmitter inside should not exceed 80 or 85 °C according to transmitter type.