

T1502

Thermocouple Temperature Sensors with Thermowells without/with Transmitters

- Thermocouple J, K
- Measuring range -20 to +600 °C
- Accuracy class 1, 2 according to EN 60584-2
- Head form B according to DIN (Al alloy or stainless steel)
- Thermowell and extension piece material: stainless steel DIN 1.4541
- Selectable thermowell length
- Housing IP 54, IP 65, IP 68
- Optional headmounted programmable transmitter with output 4 to 20 mA, including circuit isolation version and II 1G EEx ia IIC T4 ... T6 (ATEX) version
- Explosion proof II 1/2GD EEx d IIC T1 ... T6 ΔT5 °C (ATEX)

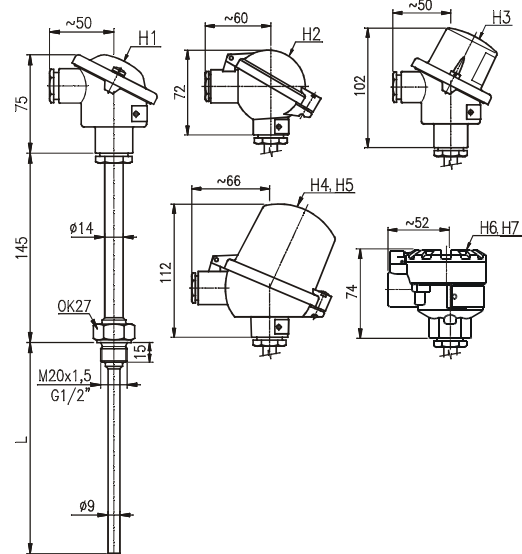

Application

Thermoelectric temperature sensors T1502 with thermowells are designed for remote measuring of temperature of flowing liquid and gaseous mediums in pipings, tanks and the like in non-hazardous or in hazardous locations with potentially explosive atmosphere of gases or dusts. Sensors thermowells in EExd version can be situated in Zone 0 (20), Zone 1 (21) and Zone 2 (22) according to EN 60079-10. Other parts of sensors (head, extension piece, connecting screw, measurement insert) can be situated in Zone 1 (21) and Zone 2 (22). They can be supplied with or without 4 to 20 mA headmounted transmitter or terminal board for connection wire.

Description

A single or dual thermocouple type J or type K which is placed in the measuring insert stem and connected to a terminal block inside the head form B according to DIN. There is made use of rise of thermoelectric voltage. Its size depends on a temperature difference between a measuring junction and a cold junction of the thermocouple. With a version with a transmitter the thermoelectric voltage is converted to a unified linear current signal of 4 to 20 mA. The thermometer should be mounted on piping by a connecting pipe union into a straight or an oblique welded-on piece.

Technical Specifications

Thermocouple:

J, K, accuracy class 1 or 2 according to EN 60584-2

Measuring Range:

- 200 to +600 °C - thermocouple J (material 1.4541)
- 200 to +600 °C - thermocouple K (material Inconel 600)
- 50 to +450 °C EExd version (Code ED)

Output signal: linearized 4 to 20 mA ¹⁾

Dielectric Strength: 500 V eff

Electrical insulation resistance:

min. 100 MΩ according to EN 61515,
for temperature (25 ±10)°C, max. 80 % relative humidity

Materials: Head - Aluminium alloy (H1, H2, H3, H4, H5, H6)
- Stainless steel 42 29 31 (H7)
Stem - Stainless steel DIN 1.4541
Inside wiring - Cu

Housing: IP 54, IP 65, IP 68 (according to head)

Operation conditions

Maximal Temperature of Head:

- 100 °C (without transmitter)
- 80 °C (with transmitter PT-031 and P3301)
- 85 °C (with transmitter P5102, P5201 and P5310)

Ambient temperature for EExd version (Code ED):

-40 to +65 °C

Application of load thermowell in flowing medium

Flow Speed of Medium:

- Water up to 3 m/s
- Steam up to 25 m/s

For L = 630 not declared.

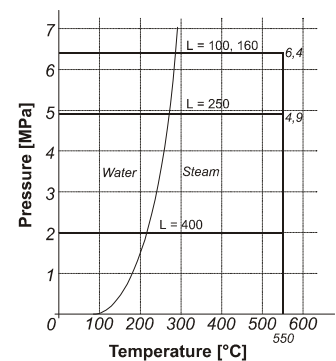

¹⁾ ... Only for sensor with transmitter

Thermocouple Temperature Sensors T1502 with Thermowells without/with Transmitters

Ambiente temperature for EExd version (Code ED):

Customers have to assure installation of temperature sensors to do not increase of maximal surface temperature and temperature of armature influenced by outside temperature (measured medium, sun heating, etc.) defined by EN 50014 (for gases) and EN 50281 (for dusts). Customers have to calculate plus 5 °C (self heating of maximal operating energy output, $P_{\text{imax}}=1 \text{ W}$) for defining of ambient temperature. Maximal ambient temperature for electrical device of explosion group II for explosive atmosphere of gases, steams and foges see Table 1.

Maximal ambient temperature for electrical device of explosion group II for explosive atmosphere of dusts is lower value of:

- ignition temperature of dust in layer decreased of 75 °C,
- 2/3 of ignition temperature of dust in turbulent state

Table 1

Temperature Class	Max. Ambient Temperature	Max. Temperature of Measured Medium
T1	450 °C	445 °C
T2	300 °C	295 °C
T3	200 °C	195 °C
T4	135 °C	130 °C
T5	100 °C	95 °C
T6	85 °C	80 °C

Other specifications

EMC (Electromagnetic Compatibility):

According to EN 61326-1:98 / A1:99

Explosion proof (Code ED):

Ⓔ II 1/2GD EEx d IIC T1 ... T6 $\Delta T5^{\circ}\text{C}$

only for head H6, H7

Maximal permissible operating properties:

I_{imax} : 30 mA

P_{imax} : 1 W

CAUTION!

It is possible to use for EExd version other cable gland with connection thread M20x1.5 and with approving Ⓔ II 2G EEx d IIC for explosion proof version and for ambient temperature -40 to +65 °C.

It is due to lock cable against possible rotation and displacement for using with cable glands (KME1, KME2).

ATTENTION! Temperature sensors in EExd version (code ED) have not to be removed in operation, cover of head and cable gland keep tight when circuit alive!

Any construction changes of EExd version are prohibited and can be cause of explode!

Information and attention of EExd head

FTZÚ 03ATEX0297

Ⓔ II 1/2GD EExd IIC T1 ... T6 $\Delta T5^{\circ}\text{C}$

(-40°C ≤ Ta ≤ +65°C)

KEEP TIGHT WHEN CIRCUIT ALIVE!

Weight:

a) without transmitters with head H1:

Nominal lenght L: 100 ... 0.47 kg
 160 ... 0.49 kg
 250 ... 0.53 kg
 400 ... 0.58 kg
 630 ... 0.63 kg

b) with head H2 plus 0.04 kg

H3 plus 0.05 kg

H4, H5 plus 0.20 kg

H6 plus 0.16 kg

H7 plus 0.70 kg

c) with transmitter PT-031 plus 0.02 kg

with transmitter P5102 plus 0.04 kg

with transmitter P5201 plus 0.05 kg

with transmitter P3301 plus 0.04 kg

with transmitter P5310 plus 0.04 kg

Electrical Connections

B - black

G - green

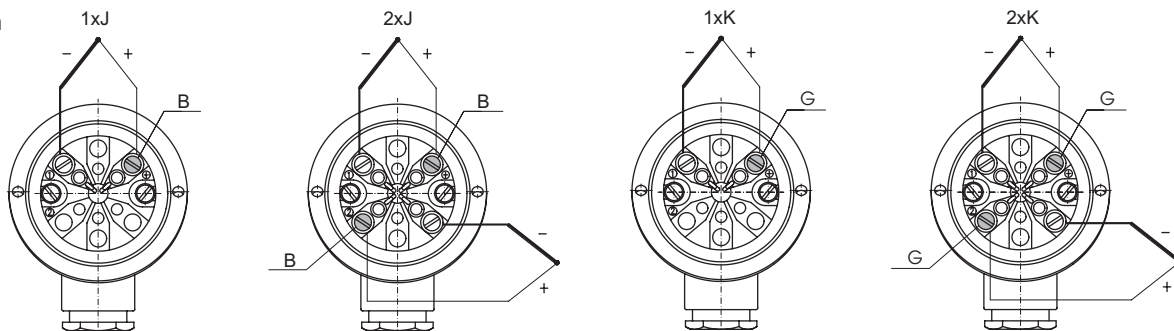

Thermocouple Temperature Sensors T1502 with Thermowells without/with Transmitters

Type	Description		
o T1502-3 →	Thermocouple Temperature Sensors with Thermowells		
Code	Thermocouple	Measuring Range	Temperature on Connection Thread
o 21 →	1x"J" (Fe-CuNi), Insulated	-200 to +600 °C	Max. +600 °C
61	2x"J" (Fe-CuNi), Insulated, Isolated Junctions	-200 to +600 °C	Max. +600 °C
o 22	1x"K" (NiCr-NiAl), Insulated	-200 to +600 °C	Max. +600 °C
62	2x"K" (NiCr-NiAl), Insulated, Isolated Junctions	-200 to +600 °C	Max. +600 °C
Code	Accuracy Class according to EN 60584-2		
6	1		
o 7 →	2		
Code	Nominal Length L [mm]		
o 110	100		
o 116 →	160		
o 125	250		
o 140	400		
o 163	630		
999	Other		
Code	Thermowell - Outside Diameter x Wall Thickness [mm]	Material	
o J10 →	∅ 9x1, Cylindrical	Stainless Steel DIN 1.4541	
J99	Other		
Code	Extension Piece - Outside Diameter x Wall Thickness [mm]	Length [mm]	Material
o N1 →	∅ 14x2.5	145	Stainless Steel DIN 1.4541
N9	Other		
Code	Head		
o H1	Al Alloy, Cable Outlet M20x1.5, Housing IP 54, with Terminal Board		
o H2	Al Alloy, Cable Outlet M20x1.5, Housing IP 65, with Terminal Board		
o H3 →	Al Alloy, with High Cap for Mounting of Transmitter ∅ 44 mm into Cap, Cable Outlet M20x1.5, Housing IP 54, with Terminal Board		
o H4	Al Alloy, with High Cap for Mounting of Transmitter up to ∅ 62 mm and High 50 mm, Span of Mounting Bolts 33 mm, Cable Outlet M20x1.5, Housing IP 65, with Terminal Board		
H5	Al Alloy, with High Cap for Mounting of Transmitter up to ∅ 62 mm and High 50 mm, Span of Mounting Bolts 33 mm, Cable Outlet M20x1.5, Housing IP 65, with Terminal Board, Outside and Inside Ground Clamp		
o H6 ¹	Al Alloy, for Transmitters ∅ 44 mm with Mounting on Bulb Flange, Thread for Cable Outlet M20x1.5, Outside and Inside Ground Clamp, without Cable Outlet, without Terminal Board, Housing IP 68		
o H7 ¹	Stainless Steel, for Transmitters ∅ 44 mm with Mounting on Bulb Flange, Thread for Cable Outlet M20x1.5, Outside and Inside Ground Clamp, without Cable Outlet, without Terminal Board, Housing IP 68		
H9	Other		
o S1 ¹	Terminal Board for Connection Wire (for Heads H6, H7)		
Code	Connection Thread		
o P1 →	M20x1.5		
o P2	G1/2"		
P9	Other		
Code	OPTIONAL ACCESSORIES		
Code	Calibration		
o KTE3	Sensor Calibration in Three Customer's Given Temperature Points (0 to +600 °C)		
KTE9	Other		
Code	Explosion proof		
ED	Explosion proof II 1/2G EEx d IIC T1 - T6, measuring range -50 to 450 °C (only with code H6, H7)		
Code	Transmitters for Headmounting		
• P5310	Programmable Transmitter P5310 with LHP Communication, Base Accuracy up to 0.1 % from Set Range (See Data Sheet No. 824)		
• PT-031	Programmable Transmitter for Thermoelectric Sensors PT-031, Base Accuracy 0.15 % from Input Range (See Data Sheet No. 471)		
• P5102 →	Programmable Transmitter P5102 H10, Base Accuracy to 0.07 % from Set Range (See Data Sheet No. 451)		
o P5102EEx	Intrinsically Safe Programmable Transmitter P5102 H10EEx, Base Accuracy to 0.07 % from Set Range (See Data Sheet No. 451)		
• P5201	Universal Programmable Transmitter P5201 H10 with Circuit Isolation, Base Accuracy to 0.05 % from Set Range (See Data Sheet No. 288)		
o P5201EEx	Intrinsically Safe Universal Programmable Transmitter P5201 H10EEx with Circuit Isolation, Base Accuracy to 0.05 % from Set Range (See Data Sheet No. 288)		
• P3301	Universal Programmable Transmitter P3301 SMART with Circuit Isolation, Base Accuracy to 0.065 % from Set Range HART Communication Interface (See Data Sheet No. 507)		
Code	Other		
• KM1	Cable Outlet, Nickel Silver, IP 68, Diameter of Cable 5 to 10 mm (for Heads H6, H7)		
• KME1	Cable Outlet EExd, Nickel Silver, IP 68, for fixed assembly Cable with Diameter 4 to 8.5 mm (for Heads H6, H7)		
• KME2	Cable Outlet EExd, Nickel Silver, IP 68, for fixed assembly Cable with Diameter 6 to 12 mm (for Heads H6, H7)		
KM9	Other Outlet		
• PK1	Lock anti pull-up cable for EExd Cable Outlet KME1		
• PK2	Lock anti pull-up cable for EExd Cable Outlet KME2		
Example of Order: T1502-3 21 7 116 J10 N1 H3 P1 P5201 H10 RL 0 °C RH 450 °C ECL			

o ... Ex Stock Version

° ... Marked Version can be Dispatched up to 10 Working Days

¹ ... Temperature transmitter is mounted directly on flange of measuring insert in lieu of ceramic terminal block when temperature sensor is supplied with head H6 or H7.