

# Flow monitor for liquid and gas *t-trend*



## Features and Benefits

- Nominal diameters DN25 ... DN1000
- Suitable for Liquids and Gases
- No moving parts – reduced maintenance
- Wide selection of Process Connections
- Wide dynamic range
- EHEDG approved. Meets 3A requirements



## Mounting and Installation

### Insertion Depth

For optimum measuring performance the active area should be positioned anywhere between 5% and 50% of the internal pipe diameter. The sensor tip should be in contact with the medium at all times.

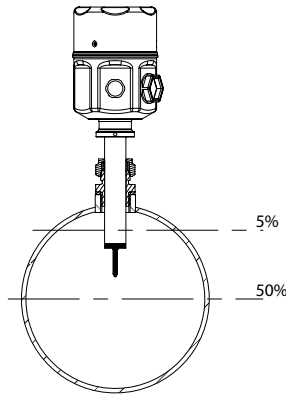

For pipe diameters <DN250

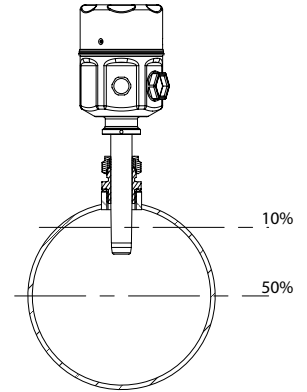

For pipe diameters ≥DN250

### Planning and Installation Guidelines

- Mount upstream of control valves, hand or isolation valves
- Ensure sensor is aligned with direction of flow (see manual)
- For liquids ensure full pipes
- Avoid areas of cavitation (liquids)
- For gases avoid areas where condensate collects
- Avoid applications with large process temperature changes
- Avoid mounting device where exposure to extreme ambient temperature changes occurs e.g. direct sunlight

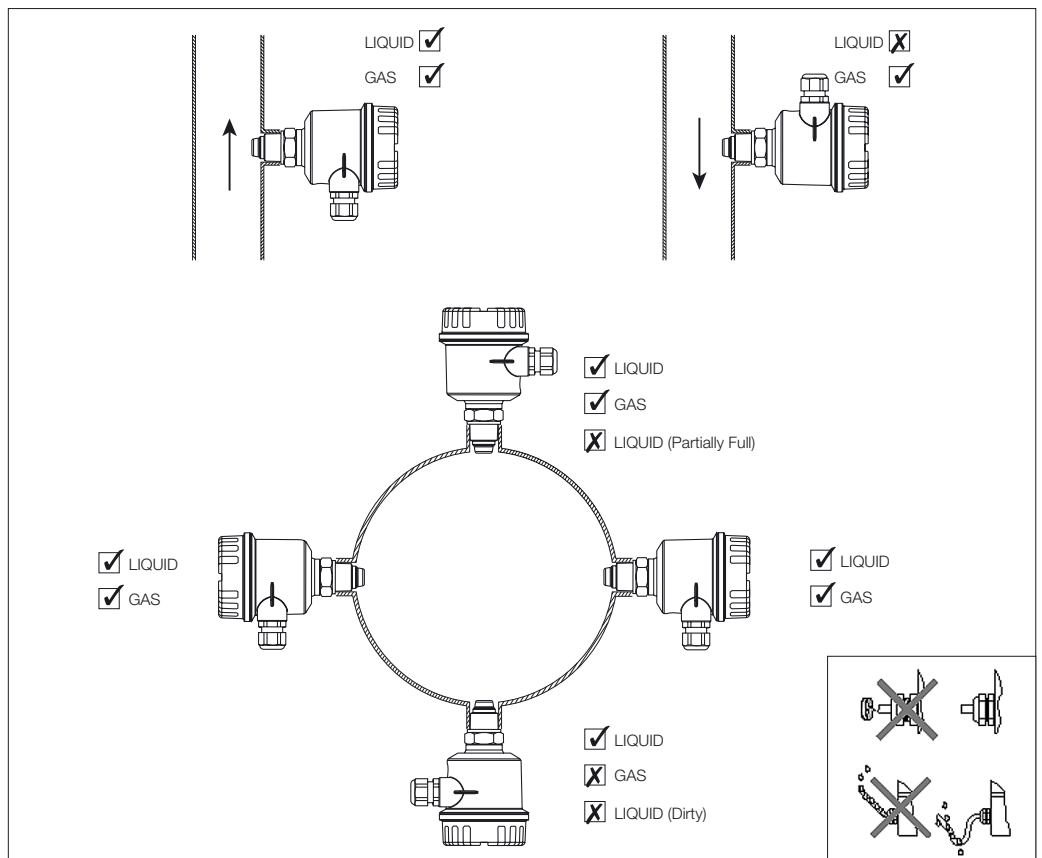

## Planning and Installation Guidelines

### Sensor Orientation

- Each process connection has an orientation mark, this should be positioned in line facing the oncoming flow.
- Sensor should be installed such that the sensing surface is in contact with the flowing medium at all times.
- There is an allowed orientation tolerance of  $\pm 5^\circ$  from centre.

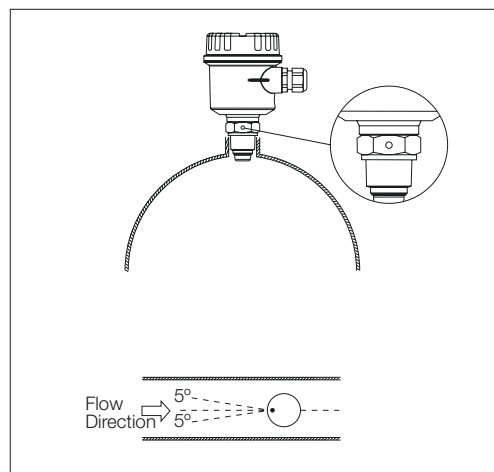

### Sanitary Sensor

- It is the responsibility of the user to ensure that the volume enclosed by the mounting boss has sufficient dimensions to ensure adequate cleaning takes place.

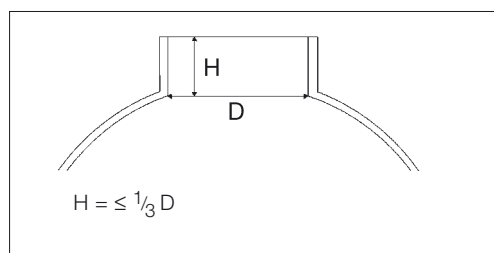

## Mounting and Installation

Avoid installing in areas of extreme flow turbulence. For example:

- Directly after bends or expansions/reductions.
- Directly downstream of isolation and control valves.
- Directly after pumps, fans and compressors.

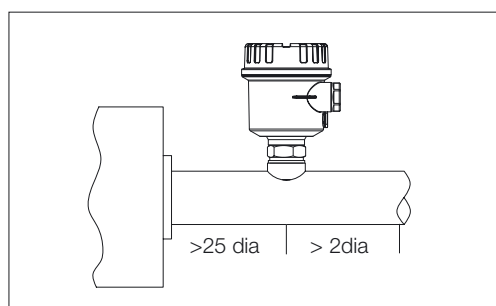
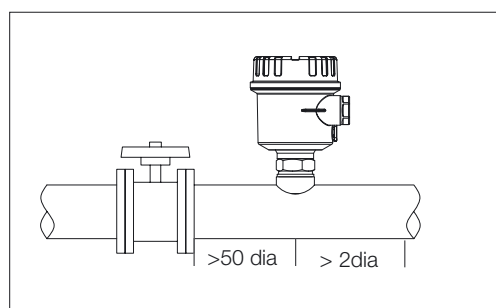
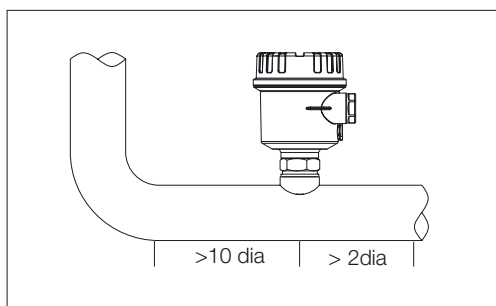

### Note:

All downstream dimensions provided only as a guideline and wherever possible greater dimensions should be considered.

**Insertion Sensor**

Process Connection  
Extended Sensor

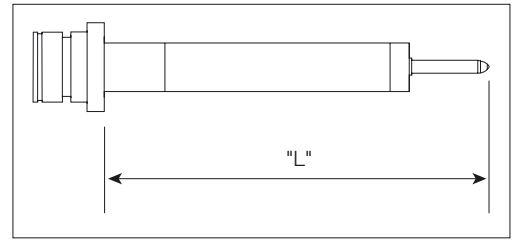

Dimensions of extended versions (L in mm)		
Sensor Option	Insertion 125mm	Insertion 235mm
Flat-Face	125	235
Probe	125	235

**Mounting Boss**

For BSP and NPT threads

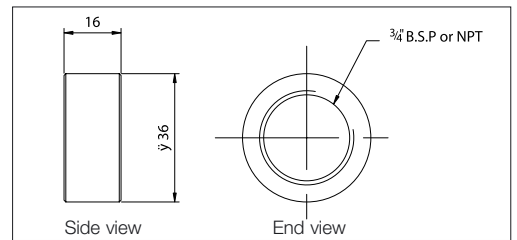

**Accessories**

**Threaded Flanges**

3/4" NPT thread for mounting a t-trend.

- Available sizes:
- DN25 PN25
  - ANSI 1" 150lbs
  - DN40 PN25
  - ANSI 1 1/2" 150lbs
  - DN50 PN25
  - ANSI 2" 150lbs

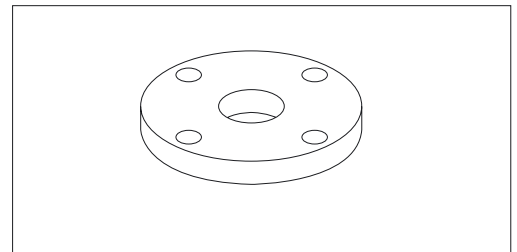

**Electrical Connection**

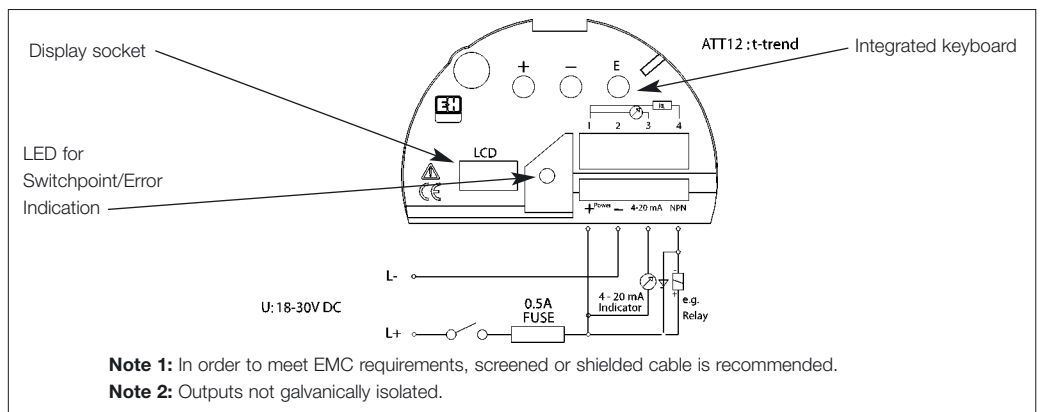

**Operation**

**LED (Light Emitting Diode)**

- Illuminates when measured flow above switchpoint.
- Off when measured flow below switchpoint.
- Flashes to indicate an error.

**LCD (Liquid Crystal Display)**

- Optional display used to indicate flow as a percentage of maximum. Also displays programming information and error codes (not essential for programming).

## Housing and Sensor

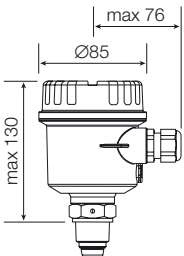
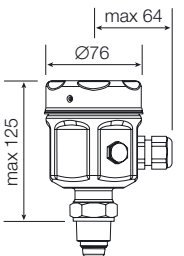
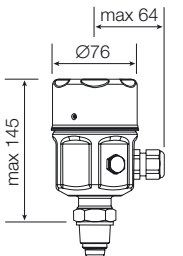
Polyester Housing No display	Steel Housing No display	Steel Housing with Extended Lid With display
		

## Process Connection

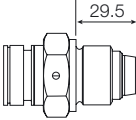
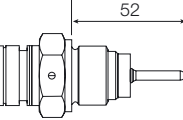
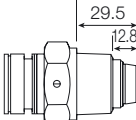
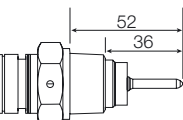
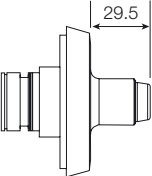
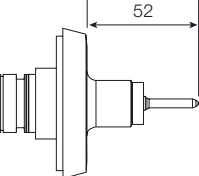
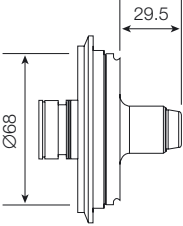
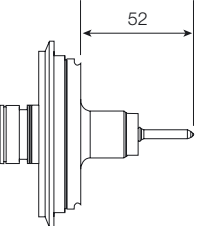
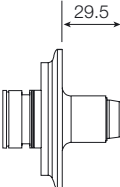
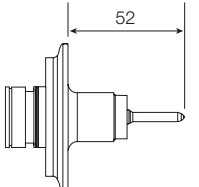
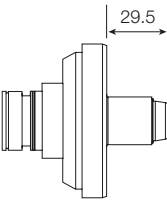
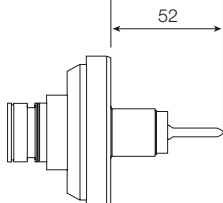
Process Connection	Dimensions with Flat-Face Sensor	Dimensions with Probe Sensor	Process Limits
BSP 3/4" (G)			max 25 bar A max 80°C
3/4" NPT			max 25 bar A max 80°C
Sanitary coupling DN40 DN50 to DIN 11851			max 25 bar A max 80°C
Varivent DN50			max 10 bar A max 80°C
Triclamp 1 1/2" 2" ISO 2852			max 16 bar A max 80°C
Aseptic coupling DN50 to DIN 11864			max 25 bar A max 80°C

All dimensions in mm

---

## Technical Data

---

<b>Process Conditions</b>	<ul style="list-style-type: none"><li>• Nominal Process Diameters: DN25 ... 1000</li><li>• Process Pressure Range: 25 Bar g (Process fitting dependent)</li><li>• Process Temperature Range: -10 to +80°C (For temperatures in excess of 80°C please contact your local E+H representative)</li></ul>
<b>Materials</b>	<ul style="list-style-type: none"><li>• Meter Body: 1.4404/1.4435/316L</li><li>• Transducers: 1.4404/1.4435/316L</li><li>• Polyester Housing: PBT-FR (polyester) with cover in PBT-FR or with transparent cover in PA 12, Seal of cover; EPDM</li><li>• Steel Housing: 1.4301 (AISI 304), seal of cover silicone</li><li>• Cable Gland: Polyamide</li></ul>
<b>Process Connections</b>	<ul style="list-style-type: none"><li>• Parallel thread BSP <math>\frac{3}{4}</math>" (includes brass <math>\frac{3}{4}</math>" compression fitting for insertion sensors only)</li><li>• Tapered thread <math>\frac{3}{4}</math>" NPT (includes brass <math>\frac{3}{4}</math>" compression fitting for insertion sensors only)</li><li>• Sanitary coupling DN40, 50 to DIN 11851</li><li>• Varivent DN50 to factory standard Tuchenhagen</li><li>• Triclamp 1 <math>\frac{1}{2}</math>", 2" to ISO 2852</li><li>• Aseptic coupling DN50 to DIN 11864</li></ul>
<b>Performance Limits</b>	<ul style="list-style-type: none"><li>• Accuracy: <math>\pm</math> 5% of full scale</li><li>• Repeatability: <math>\pm</math> 1% of full scale</li><li>• Time Response Flat Face: 5 sec rising, &lt; 5 sec falling</li><li>• Time Response Probe: 15 sec rising, 10 sec falling</li><li>• Flow Ranges Liquid: 0-3m/sec ref. to water (see note)</li><li>• Flow Ranges Gas: 0-50Nm/sec ref. to air</li></ul>
<b>Human Interface</b>	<ul style="list-style-type: none"><li>• Integrated keyboard</li><li>• Red LED to indicate switching status, flashes under fault condition</li><li>• Optional Display: 4 numeric characters with bar graph</li></ul>
<b>Electrical</b>	<ul style="list-style-type: none"><li>• Power Supply: 18-30V DC</li><li>• Power Consumption: &lt;3W</li><li>• Current Output: 4-20 mA Active output and NPN open collector max rating 30V DC/50mA</li></ul>
<b>Environment</b>	<ul style="list-style-type: none"><li>• Storage Temperature Range: -20 to +80°C (without LCD)</li><li>• Ambient Temperature Range: -10 to +65°C (without LCD)</li><li>• Degree of Protection: Polyester and steel housings: IP66 to EN 60529</li><li>• Vibration Resistance: Up to 1g, 10....150Hz to IEC 60068-2-6</li><li>• Shock Resistance: to IEC 60068-2-31</li><li>• Electromagnetic Compatibility (EMC): IEC 801 part3: E = 10V/m (30MHz...1GHz)</li></ul>
<b>Approvals</b>	EHEDG, all wetted materials FDA listed. Meets the requirements of 3A.
<b>Approvals Pending</b>	CSA General Approval, FM General Approval.

**Note:** Standard meter rated 0-2m/sec ref to water.

## Performance and Selection

### Product Structure ATT12-

#### Approvals

- A** For use in non-hazardous areas
- B** FM General Approval (pending)
- C** CSA General Approval (pending)
- Y** Special – please specify

#### Sensor Form

- 11** Flat face sensor, 2m/sec (Liquid)
- 12** Flat face sensor, insertion 125mm, 2m/sec (Liquid)
- 13** Flat face sensor, insertion 235mm, 2m/sec (Liquid)
- 21** Probe sensor, 50Nm/sec (Gas)
- 22** Probe sensor, insertion 125mm, 50Nm/sec (Gas)
- 23** Probe sensor, insertion 235mm, 50Nm/sec (Gas)
- 31** Flat face sensor, 3m/sec (Liquid)
- 32** Flat face sensor, insertion 125mm, 3m/sec (Liquid)
- 33** Flat face sensor, insertion 235mm, 3m/sec (Liquid)
- 99** Special – please specify

#### Process Connection

(Material 1.4435/316L unless stated)

- D1** G 3/4" BSP, (Boss Included)  
(Boss suitable for DN40 to DN1000)
- D2\*** G 3/4" BSP, Brass (Boss Included) Brass  
compression fitting for insertion sensor only
- D3** G 3/4" BSP
- F1** NPT 3/4" (Boss Included)  
(Boss suitable for DN40 to DN1000)
- F2\*** NPT 3/4", Brass (Boss Included) Brass  
compression fitting for insertion sensor only
- F3** NPT 3/4"
- J1** DN40 Dairy coupling DIN 11851
- K1** DN50 Dairy coupling DIN 11851
- L1** Varivent >=DN50
- M1** Tri Clamp 1 1/2" ISO2852
- N1** Tri Clamp 2" ISO2852
- P1** DN50 Aseptic coupling DIN 11864-1
- Y9** Special – please specify
- \*** Stainless steel available on request

#### Surface Finish, Wetted Parts

- 1** Standard Metal Finish
- 2** Ra<1.5 µm/120 grit
- 3** Ra<0.8 µm/150 grit (3A/EHEDG)
- 5** Ra<1.5 µm/120 grit, O<sub>2</sub> duty
- 6** Ra<0.8 µm/150 grit, O<sub>2</sub> duty (3A/EHEDG)
- 7** Standard Metal Finish, O<sub>2</sub> duty
- 9** Special – please specify

#### Electronics & Outputs

- A** 4-20 mA and NPN transistor o/p no  
display 18-30V DC
- B** 4-20 mA and NPN transistor o/p 4 digit  
LCD display 18-30V DC  
St. St. Housing only
- Y** Special – please specify

#### Housing & Cable Entry

- 4D** Polyester Housing IP66 M20 Gland
- 4H** Polyester Housing NEMA4X NPT  
1/2" entry
- 6D** SS304 Housing IP66 M20 Gland
- 6H** SS304 Housing NEMA4X NPT 1/2" entry
- 9Y** Special – please specify

#### Documentation

- 1** Standard Documentation
- 2** EN10204-2.3 Pressure test  
1.5 x pressure rating for 3 minutes
- 9** Special – please specify

ATT12-

← Order Code

#### United Kingdom

Endress+Hauser Ltd.  
Floats Road  
Manchester M23 9NF  
United Kingdom  
Tel: 0161 286 5000  
Fax: 0161 998 1841  
www.uk.endress.com

#### All Other Countries

Endress+Hauser  
GmbH+Co  
Instruments International  
Colmarer Str 6  
D-79576 Weil am Rhein  
Germany  
Tel: +49 (7621) 97 5 02  
Fax: +49 (7621) 97 53 45  
www.ii.endress.com

Endress + Hauser

The Power of Know How

